

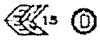

THIS INFORMATION IS CONFIDENTIAL AND PROPRIETARY TO CW INDUSTRIES INCORPORATED AND ITS AFFILIATES. IT MAY NOT BE DISCLOSED TO ANYONE, OTHER THAN CW INDUSTRIES PERSONNEL, WITHOUT WRITTEN AUTHORIZATION FROM CW INDUSTRIES INCORPORATED, SOUTHAMPTON, PENNSYLVANIA USA.

Rating	16(4)A 250V AC	  US	Mounting Hole 	Circuit 
Contact Resistance	50m ohm Max.			
Insulation Resistance	DC 500V 100M ohm Min.			
Dielectric Strength	AC 1500V 1 minute			
Switch Function	4P DPST (ON) - OFF			
Operation Temp.	0° C ~ 85° C			

() = Momentary Function

MATERIAL:

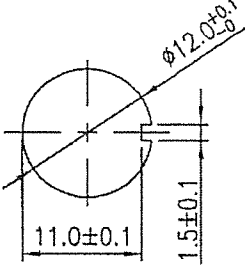
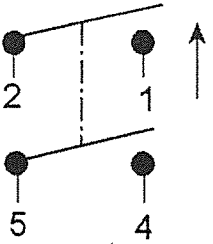
Frame: Nylon 6/6, Black
 UL Flame: 94-V0
 Lever: Nylon 66+30%GF
 UL Flame: 94-V0
 Terminal: Copper Alloy

Water proof and Dust Proof
 to fit IP-56

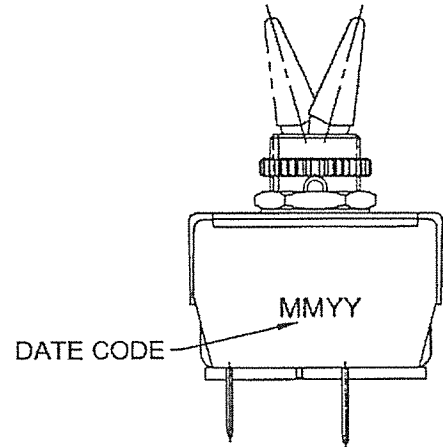
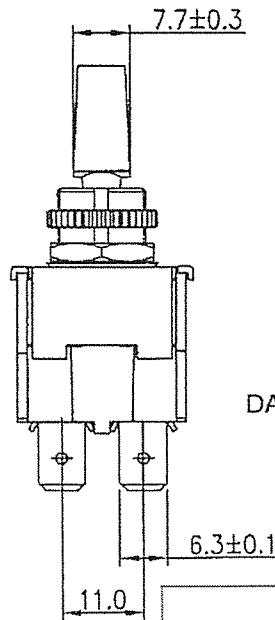
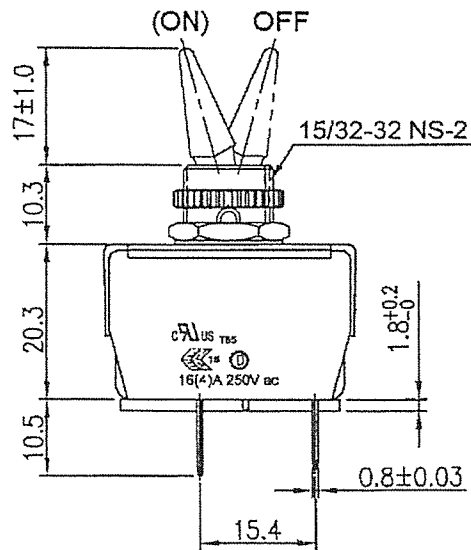
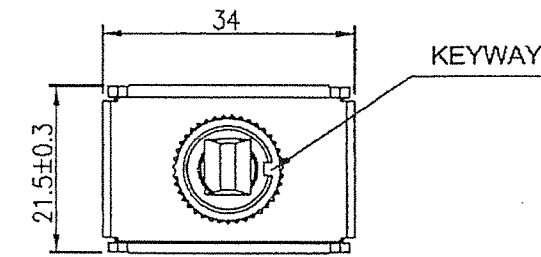

Tolerances Unless Otherwise Specified +/-0.5.

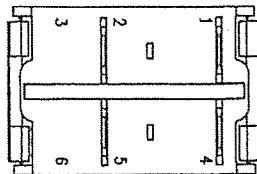

Order Chart						
Series	Lever Type Plastic			Knuri Nut		
GTS448	S	3	01	AHR		
Function				Hex Nut		
Term. Type .250" SQ				No Barrier		

RoHS Compliant

R13-448S-3-01A-HR

2 | Updated Order Chart, SCI part number & CWI logo APhilip 02/06/23

1 | Updated material notes. 3-21-13.

CW INDUSTRIES
 Southampton, Pa. 18966
 Tel 215.355.7080/www.cwind.com

Date Drawn: 8/13/12

Rev. 2

Unit: mm

Checked By: *G. Gold*

Title: **TOGGLE SWITCH**

CW P/N: **GTS448S301AHR**