

THIS INFORMATION IS CONFIDENTIAL AND PROPRIETARY TO CW INDUSTRIES INCORPORATED AND ITS AFFILIATES. IT MAY NOT BE DISCLOSED TO ANYONE, OTHER THAN CW INDUSTRIES PERSONNEL, WITHOUT WRITTEN AUTHORIZATION FROM CW INDUSTRIES INCORPORATED, SOUTHAMPTON, PENNSYLVANIA USA.

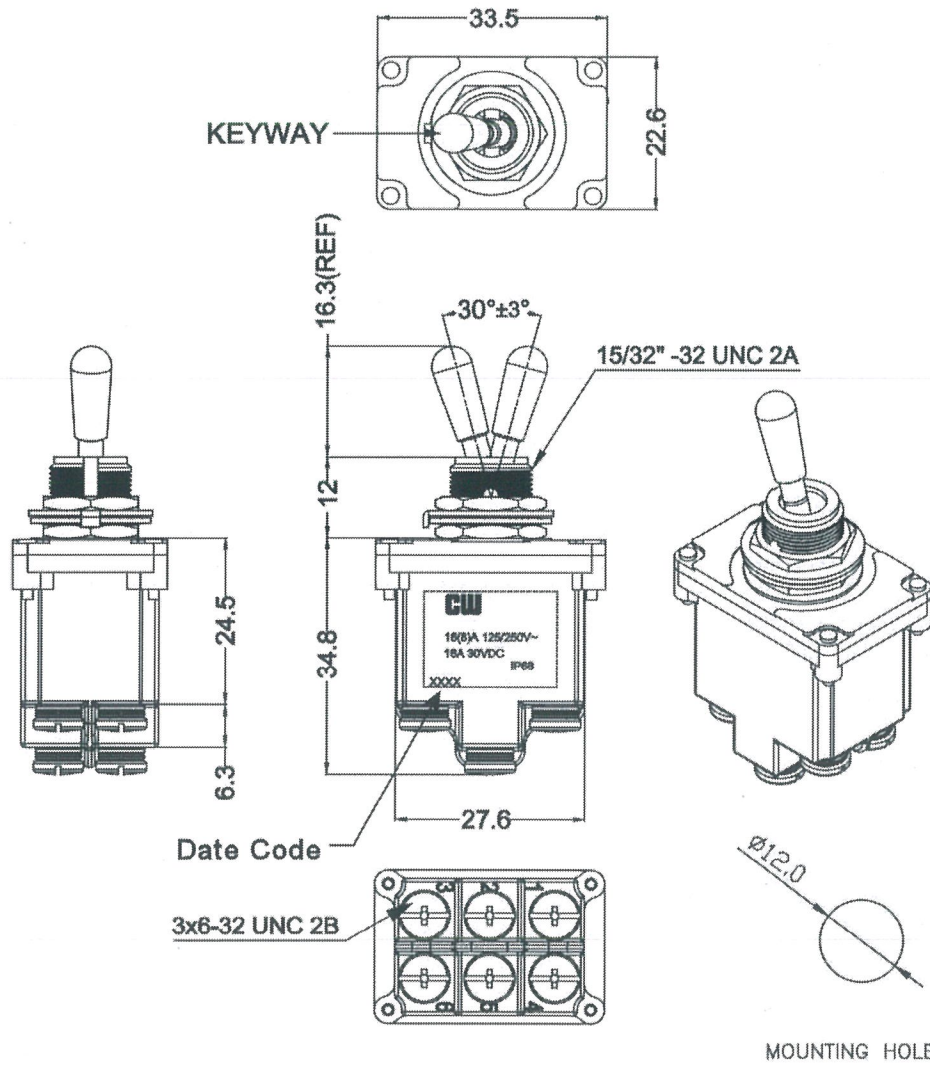

Rating: 16(8)A 125/250V~ T55
 Electrical Life: 10,000 cycles
 Mechanical Life: 50,000 cycles
 Contact resistance: 20mΩ Initial (MAX),
 Insulation resistance: 500VDC - 100MΩ (MIN).
 Dielectric Strength:
 (1) 1500VAC For 1 minute (Terminal to Enclouse)
 (2) 500VAC For 1 minute (Terminal to Terminal)
 Degree of protection: IP68 (Above the panel)
 Actuator: Brass/Dull Nickel Plated

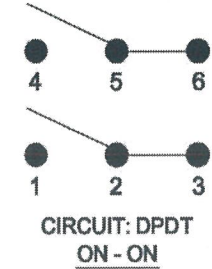

SWITCH FUNCTION	
ON	ON
1-2	2-3
4-5	5-6

Order Chart			
Series	Terminal Type	Label Type	
GTB4	B 5 3 C		
Lever Type	Position/Function		

NOTE: TOLERANCES UNLESS OTHERWISE SPECIFIED : ± .02 / 0.5 (mm).

MASTER

TB4-AB53-1C

CW INDUSTRIES
 Southampton, Pa. 18966
 Tel 215.355.7080/www.cwind.com

Date Drawn: DW 7/19/23 Rev. 0
 Title: **TOGGLE SWITCH**

Unit: mm Checked By: *G. GULD*
 CW P/N: **GTB4B53C**