

THIS INFORMATION IS CONFIDENTIAL AND PROPRIETARY TO CW INDUSTRIES INCORPORATED AND ITS AFFILIATES. IT MAY NOT BE DISCLOSED TO ANYONE, OTHER THAN CW INDUSTRIES PERSONNEL, WITHOUT WRITTEN AUTHORIZATION FROM CW INDUSTRIES INCORPORATED, SOUTHAMPTON, PENNSYLVANIA USA.

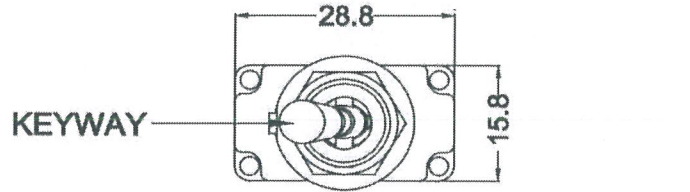

Rating: 16(8)A 125/250V~ T55
 Electrical Life: 10,000 cycles
 Mechanical Life: 50,000 cycles
 Contact resistance: 20mΩ Initial (MAX),
 Insulation resistance: 500VDC - 100MΩ (MIN).
 Dielectric Strength:
 (1) 1500VAC For 1 minute (Terminal to Enclosure)
 (2) 500VAC For 1 minute (Terminal to Terminal)
 IP68 Rated (Above the panel)
 Actuator: Brass/Dull Nickel Plated

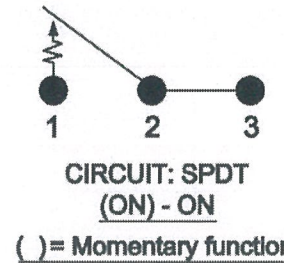
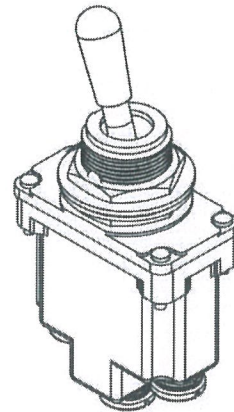
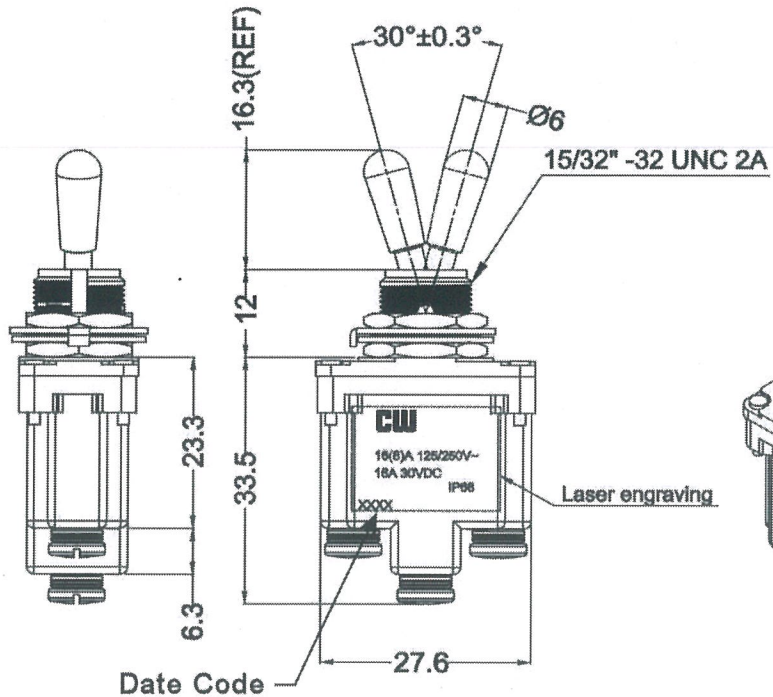

SWITCH FUNCTION	
(ON)	ON
(1 - 2)	2 - 3

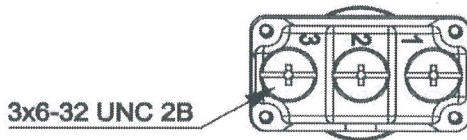
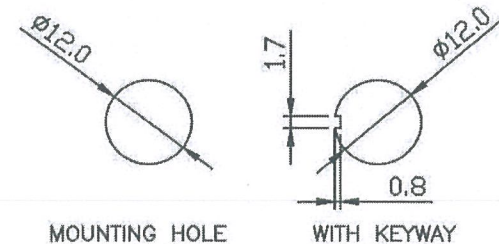

Order Chart				
Series	Lever Type	Position/Type	Function	Label Type
GTB2	B	5	8	C

NOTE: TOLERANCES UNLESS OTHERWISE SPECIFIED : ± .02 / 0.5 (mm).

RoHS Compliant

TB2-AB58-1C

MASTER

CW INDUSTRIES
 Southampton, Pa. 18966
 Tel 215.355.7080/www.cwind.com

Date Drawn: DW 4/11/23

Rev. 1

Unit: mm

Checked By: *G. GULD*

Title: **TOGGLE SWITCH**

CW P/N: **GTB2B58C**

1 Added Date Code. DW 7/20/23