

THIS INFORMATION IS CONFIDENTIAL AND PROPRIETARY TO CW INDUSTRIES INCORPORATED AND ITS AFFILIATES. IT MAY NOT BE DISCLOSED TO ANYONE, OTHER THAN CW INDUSTRIES PERSONNEL, WITHOUT WRITTEN AUTHORIZATION FROM CW INDUSTRIES INCORPORATED, SOUTHAMPTON, PENNSYLVANIA USA.

Rating	16A 125VAC, 10A 250VAC
Contact Resistance	50m ohm Max.
Insulation Resistance	DC 500V 100M ohm Min.
Dielectric Strength	AC 1500V 1 minute
Operation Temp.	- 20°C ~ 85°C
Switch Function	3P SPDT ON - OFF - ON

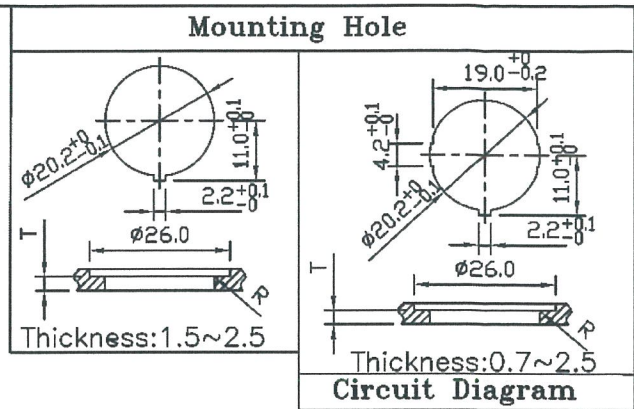

***MATERIAL:**
 Frame: Black, Nylon 66 (94-V2)
 Actuator: Black, PC (94-V2)
 Waterproof rubber: Black, Silicone
 Terminals: Silver plated, Copper alloy
 Hot Stamping: White, || O | (P/n -76)
 Waterproof: IP65

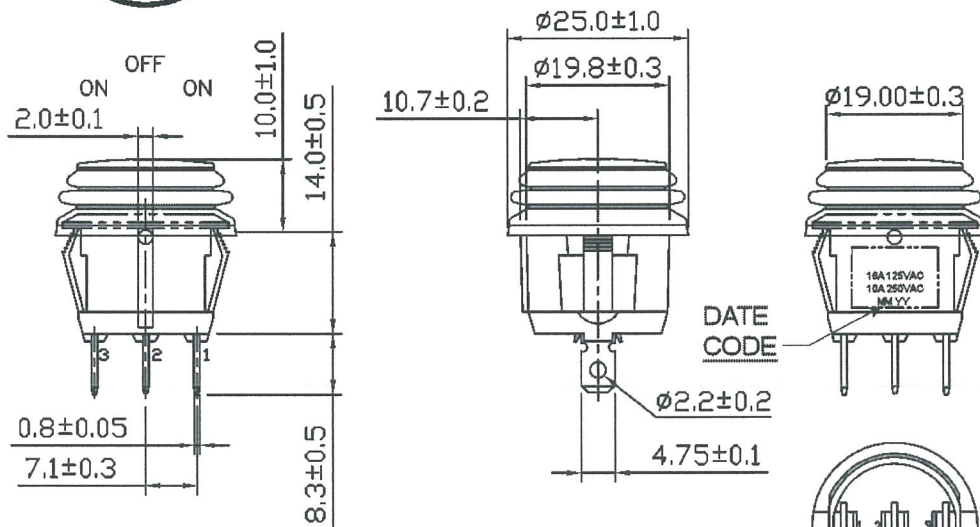

Order Chart

Series	Terminal Type
GRB112 D8 02 B B	
Function	Actuator Color
Frame Color	

Orientation Key

RoHS Compliant



R13-112D8-02-BB-76

3	Removed CW logo & added order chart. DW 11/18/22
2	Added Ratings & Date Code to Side of Housing. 9/30/10

CW INDUSTRIES
 Southampton, Pa. 18966
 Tel 215.355.7080/www.cwind.com

Date Drawn: 4/03/08

Rev. 3

Unit: mm

Checked By: *G. GULD*

Title: **ROCKER SWITCH**

CW P/N: **GRB112D802BB**