

# GPB526 Pushbutton Switch

IP56

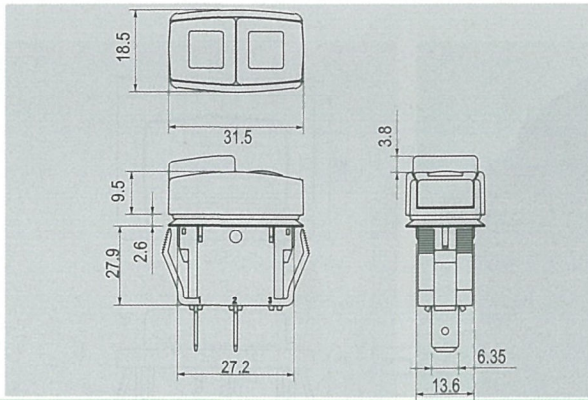
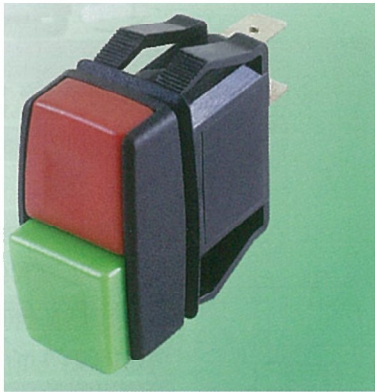

<b>Rating</b>
16A 125V AC 1/3 HP 10A 250V AC 1/2 HP 10(4)A 250V AC
<b>Contact resistance</b>
50mΩ Max
<b>Insulation resistance</b>
DC 500V 100MΩ Min
<b>Dielectric strength</b>
AC 1500V 1 minute
<b>Cut-out</b>

## FEATURES

- \* MATERIAL: Frame and Actuator are nylon (UL flame:94V-2). Terminals are silver plated brass.
- \* Illuminated actuators are molded in PC, available with red, amber, green, blue and white colors.
- \* Snap-in mounting, easy to install switch into panel.
- \* Watertight and dustproof to fit IP56.
- \* Watertight IPX6 of this switch is effective by the mounting panel sealed only.
- \* Application: Vacuum cleaner, machine.

	X	Y
	X	Y
0.75-3.0	27.6-0.1	13.8+0.1
3.0-4.0	27.8-0.1	13.8+0.1
4.0-5.0	28.0-0.1	13.8+0.1

FUNCTION		TERMINAL
<b>A</b>		0 1  .250" SQ
<b>B</b>		0 5  SO
<b>C</b>		