

DIMENSIONS IN INCHES (MILLIMETERS)  
DO NOT SCALE DRAWING .....

Dwg. No.  
**G-107SI-0005**

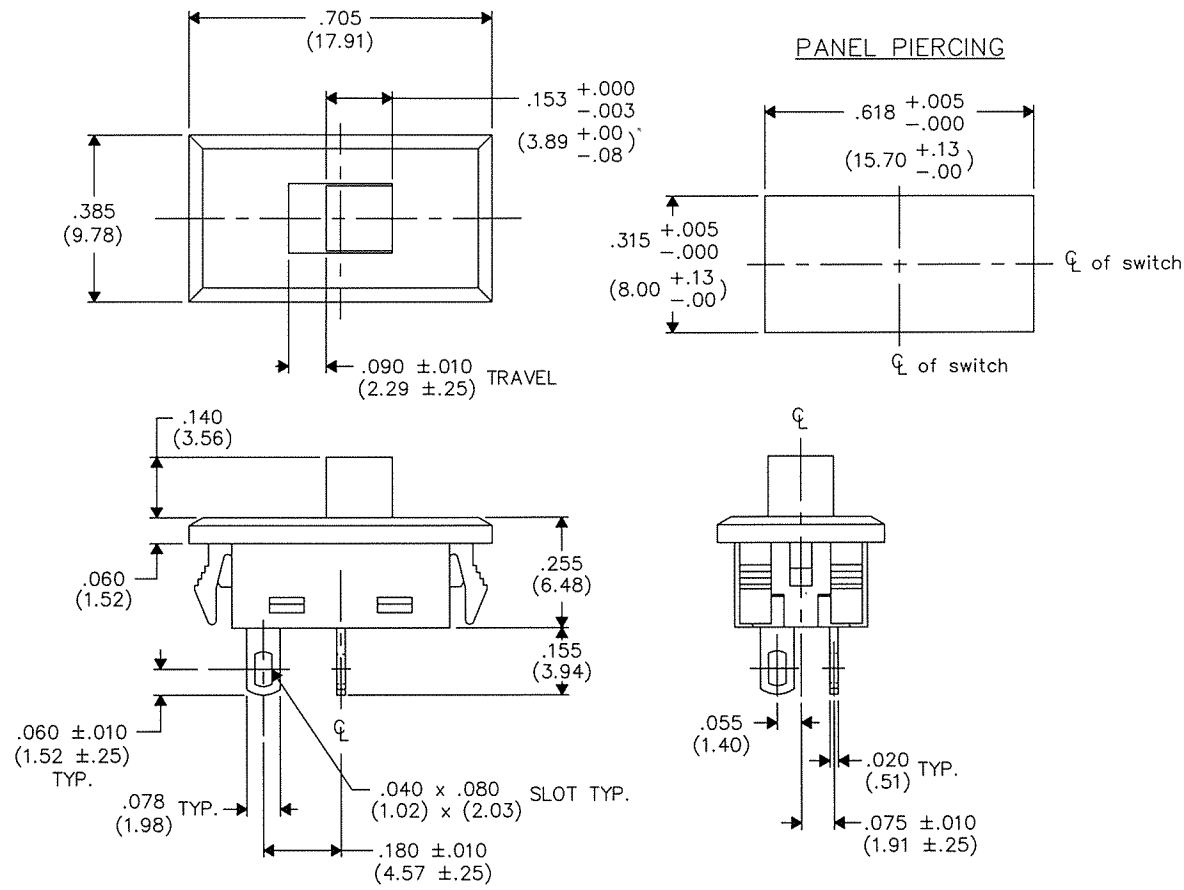

FORM-B  
 REVISIONS  
 0  
 RELEASED  
 DGW 8-08-94  
 RBK

**ATTENTION**  
 THIS DRAWING AND ITS ATTACHMENTS, IF ANY, ARE PROPRIETARY TO CW INDUSTRIES AND DESCRIBE DESIGNS THAT ARE CONFIDENTIAL AND MUST NOT BE DISCLOSED UNLESS AUTHORIZED, IN WRITING, BY AN OFFICER OF CW INDUSTRIES.....

**CW INDUSTRIES**  
 Southampton, Pa. 18966

TOLERANCES UNLESS OTHERWISE SPECIFIED	
2 Place decimal ±.010	METRIC
3 Place decimal ±.005	1 Place dec. ±.25mm
Angles ..... ± 1'	2 Place dec. ±.13mm

Made for: CW IND.  
 Drawn by: DGW 8-08-94  
 Checked by: GG 8-10-94  
 Approval: RBK 8-10-94

Title: **MICRO SWITCH ASSEMBLY SNAP-IN S.P. - S.T.**

Division: **SWITCH**

Dwg. No. **G-107SI-0005**